

# TAI-SAW TECHNOLOGY CO., LTD.

No. 3, Industrial 2nd Rd., Ping-Chen Industrial District,  
Taoyuan, 324, Taiwan, R.O.C.

TEL: 886-3-4690038 FAX: 886-3-4697532

E-mail: [tstsales@mail.taisaw.com](mailto:tstsales@mail.taisaw.com) Web: [www.taisaw.com](http://www.taisaw.com)

## Product Specifications Approval Sheet

Product Name: 91.85 MHz 50MHz BW SMD 13.3 x 6.5 mm SAW IF Filter

TST Parts No.: TB1107A

Customer Parts No.: \_\_\_\_\_

Customer signature required
Company: _____
Division: _____
Approved by : _____
Date: _____

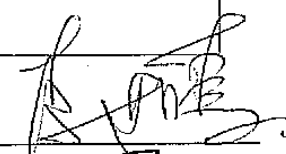
Checked by: \_\_\_\_\_ Kazuma Lee 

Approval by: \_\_\_\_\_ Francis Chen 

Date: \_\_\_\_\_ 10 / 08 / 2012

1. Customer signed back is required before TST can proceed with sample build and receive orders.
2. Orders received without customer signed back will be regarded as agreement on the specifications.
3. Any specifications changes must be approved upon by both parties and a new revision of specifications shall be released to reflect the changes.



# TAI-SAW TECHNOLOGY CO., LTD.

No.3, Industrial 2nd Rd., Ping-Chen Industrial District, Taoyuan, Taiwan, R.O.C.

TEL: 886-3-4690038 FAX: 886-3-4697532

E-mail: [tstsales3@mail.taisaw.com](mailto:tstsales3@mail.taisaw.com) Web: [www.taisaw.com](http://www.taisaw.com)

SAW Filter 91.85MHz 50MHz BW (SMD 13.3x6.5 mm)

MODEL NO.: TB1107A

REV. NO.1

## A. MAXIMUM RATING:

1. Operating temperature range: -30°C to 85°C
2. Storage temperature range: -40°C to 85°C
3. Input Power Level : 10 dBm
4. Maximum DC Voltage : 10V

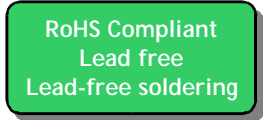

Electrostatic Sensitive Device

## B. Characteristics :

Item	Unit	Min.	Type.	Max.
Center frequency, <b>Fc</b>	MHz	-	91.85	-
Insertion Loss, <b>IL</b>	dB	-	23.5	26.0
1dB Bandwidth	MHz	50	57	-
40dB Bandwidth	MHz	-	65	75
Passband Ripple Fc+/- 25MHz	dB	-	0.7	1.2
Absolute group Delay	us	-	0.8	-
Group Delay variation Fc+/- 25MHz	ns	-	30	-
Attenuation (Reference level from minimum Insertion loss )				
DC ~ 51.5MHz	dB	35	40	-
131.5MHz ~ 170MHz	dB	35	40	-
170MHz ~ 380MHz	dB	25	35	-
380MHz ~ 550MHz	dB	45	57	-
550MHz ~ 1000MHz	dB	45	57	-
Temperature Coefficient	ppm/°C	-	-94	-
Source Impedance	Ohm	-	50	-
Load Impedance	Ohm	-	50	-

### C. Frequency Characteristics :

#### (1) Narrow band Response:

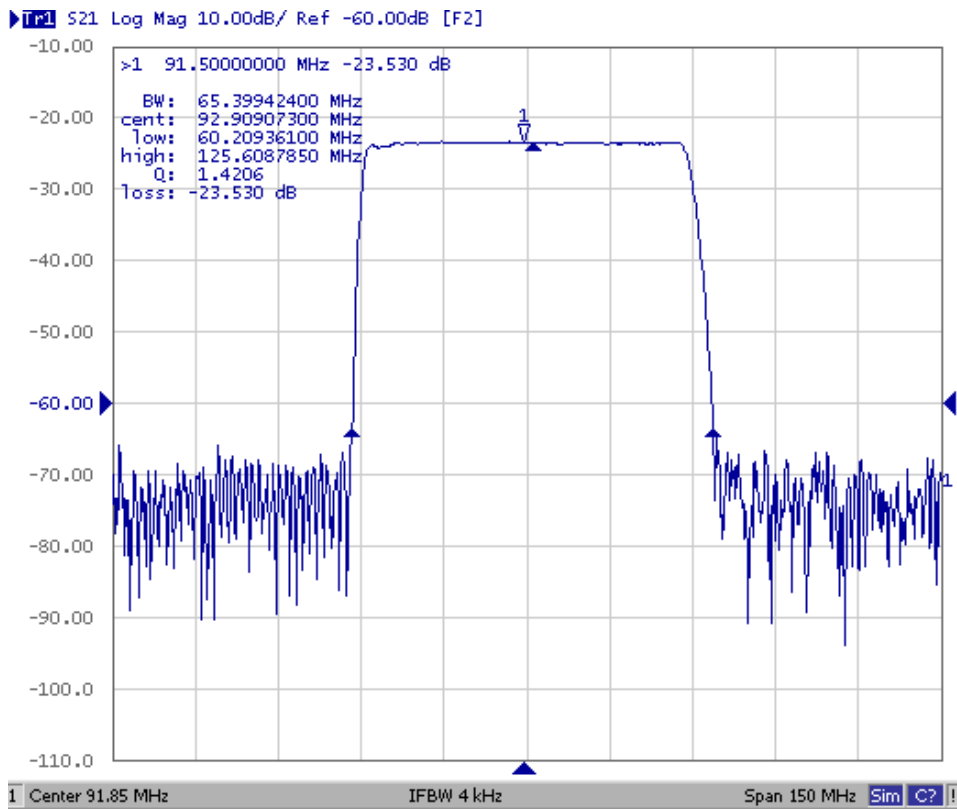

Fig1. Horizontal: 15MHz/Div Vertical: 10dB/Div

#### (2) Pass band Response and Group Delay Response:

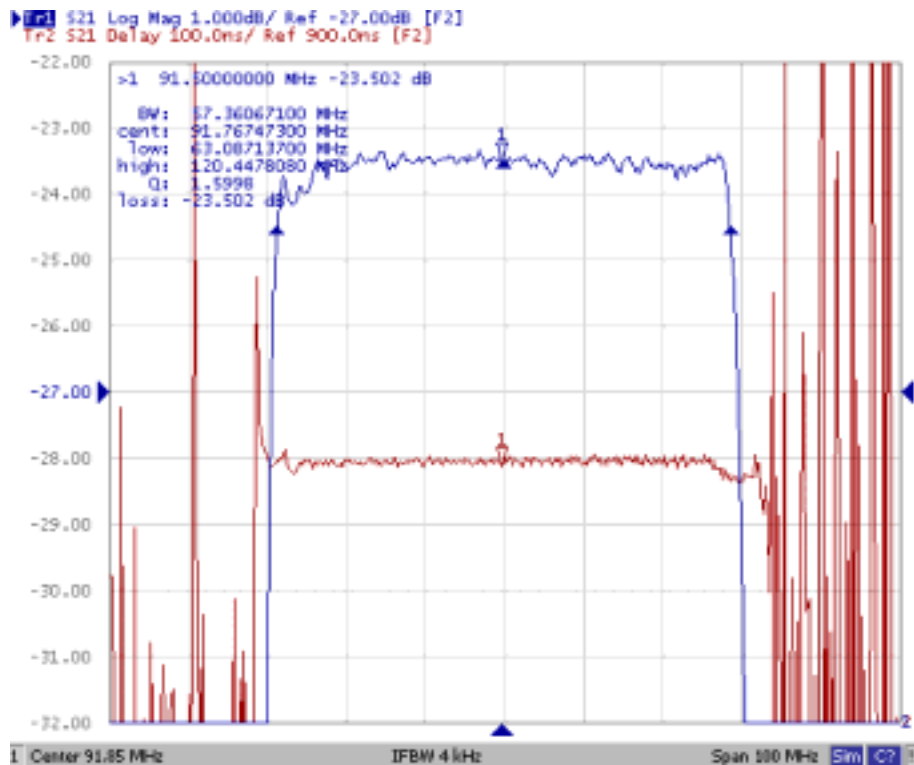

Fig2. Horizontal: 10MHz/Div Vertical: 1dB/Div  
Vertical: 100ns/Div

(3) Wide band Response:

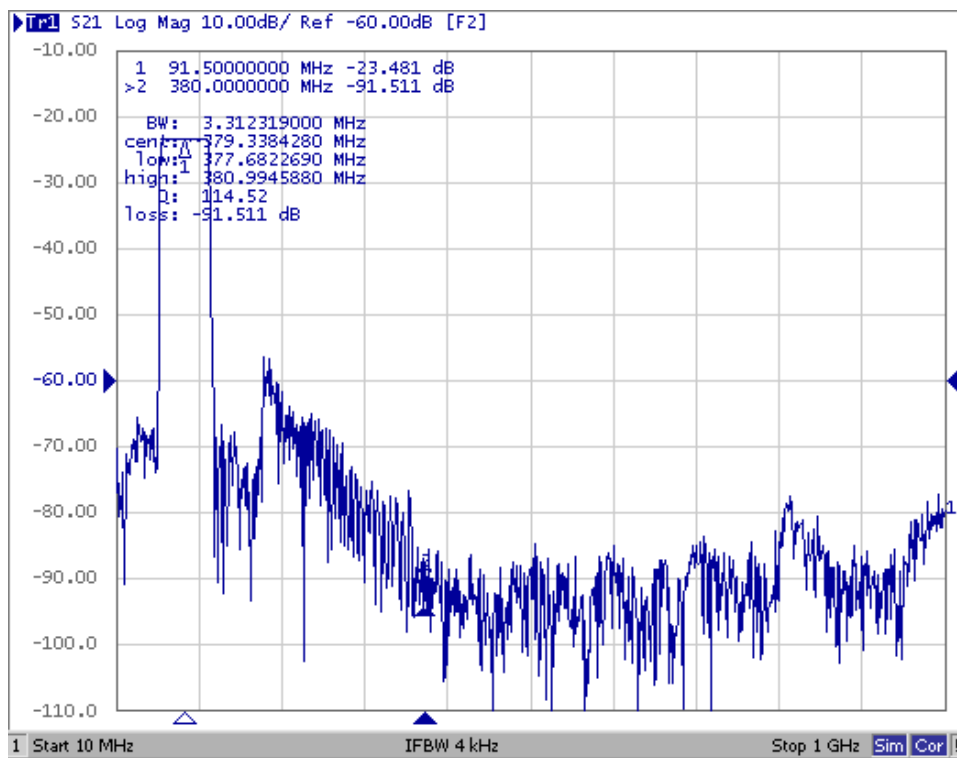
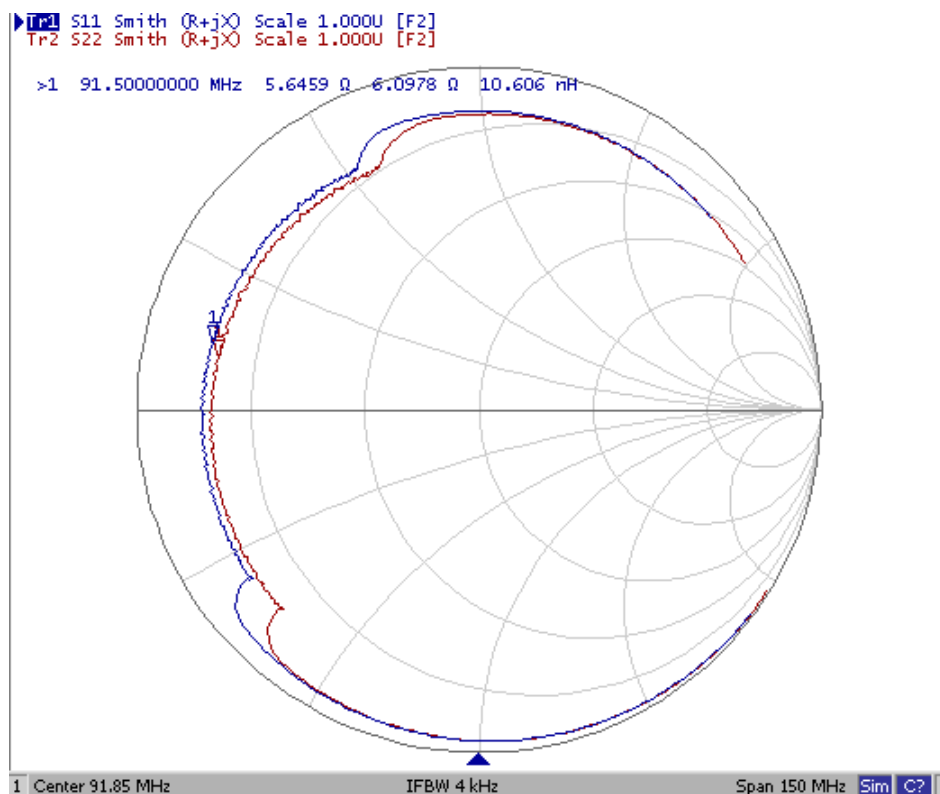
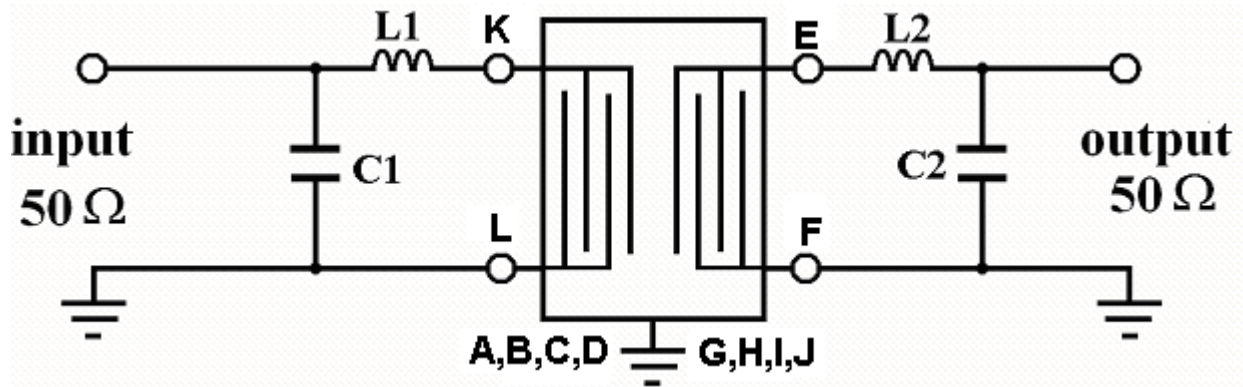

Fig1. Horizontal: 100MHz/Div Vertical: 10dB/Div

(4) Smith Chart



**D. Matching Circuit:**



$L1=56\text{nH}$   $C1=9\text{pF}$   $L2=68\text{nH}$   $C2=9\text{pF}$

**E. Outline Drawing:**

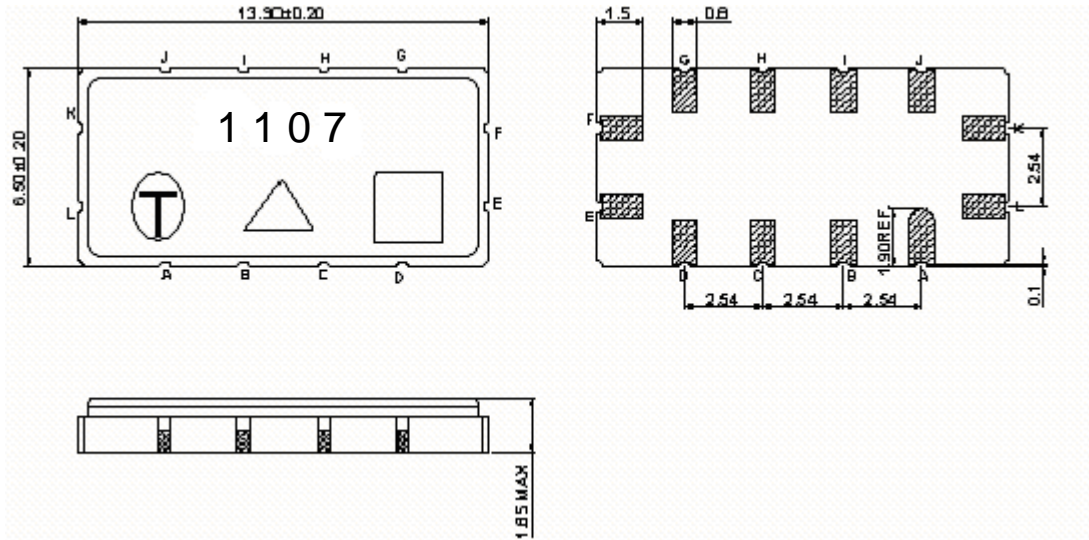

#K : Input

#L : Input Ground

#E : Output

#F : Output Ground

#A,B,C,D,G,H,I,J : Ground

: Week Code

Unit: mm

: Product / Year Code

Year	2009 2013	2010 2014	2011 2015	2012 2016
Product Code	B	b	<u>B</u>	<u>b</u>

Week Code Table

WK01	WK02	WK03	WK04	WK05	WK06	WK07	WK08	WK09	WK10	WK11	WK12	WK13
A	B	C	D	E	F	G	H	I	J	K	L	M
WK14	WK15	WK16	WK17	WK18	WK19	WK20	WK21	WK22	WK23	WK24	WK25	WK26
N	O	P	Q	R	S	T	U	V	W	X	Y	Z
WK27	WK28	WK29	WK30	WK31	WK32	WK33	WK34	WK35	WK36	WK37	WK38	WK39
a	b	c	d	e	f	g	h	i	j	k	l	m
WK40	WK41	WK42	WK43	WK44	WK45	WK46	WK47	WK48	WK49	WK50	WK51	WK52
n	o	p	q	r	s	t	u	v	w	x	y	z

F. PCB Footprint:

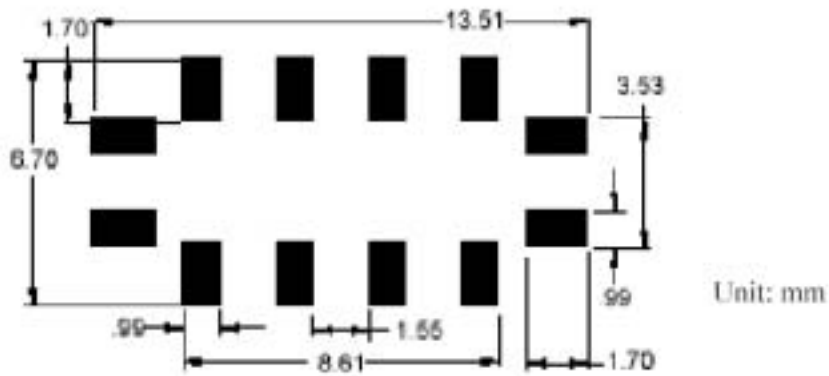

G. PACKING:

1. REEL DIMENSION

(Please refer to FR-75D10 for packing quantity)

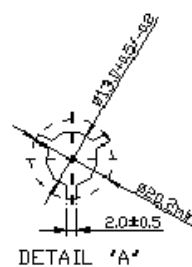
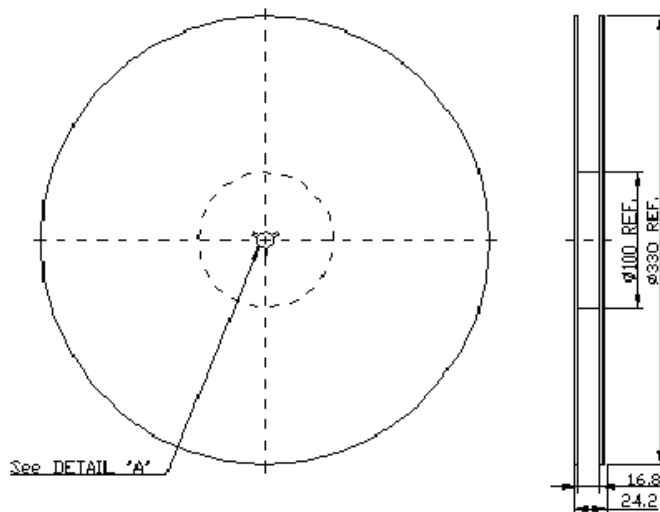

## 2. TAPE DIMENSION

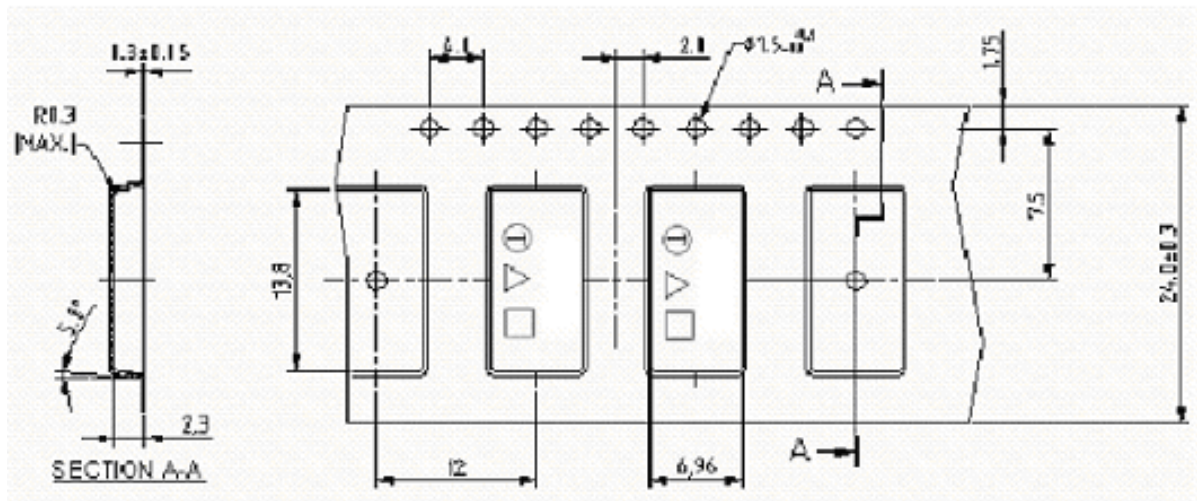

Direction of feed →

### I. RECOMMENDED REFLOW PROFILE:

